

JDN AIR HOISTS PROFI





Carrying capacities: 550 lbs up to 100+ metric tons Air pressure: 65 psi or 85 psi versions available

Proven in practice: JDN Air Hoists **PROFI** Series are superior the most demanding environments. The **PROFI** Series scores well with its 100% duty rating and explosion protection as standard. This important advantage ensures JDN Air Hoists are especially suitable for applications in hazardous areas.

JDN Air Hoists **PROFI** Series are very robust and therefore suitable for tough industrial applications even in continuous working processes. According to your requirements there are various control systems available. For traversing loads there are also different trolley designs to meet your particular demands.

Where the JDN PROFI excellence has been proven

Aircraft construction, assembly lines, chemical industry, dairies, electro plating, explosives and pyrotechnics industry, food industry, foundries, furniture industry, glass industry, lacquer and varnish factories, match industry, mechanical engineering, auto industry, oil storage plants, on- and offshore, paint shops, paper industry, power plants, refineries, sawmills, shipyards, space industry, tempering plants, textile industry.



Standard Features

- Suitable for application in hazardous areas
- Sensitive infinitely variable speed control for the precise positioning of loads
- Easy operation
- Suitable for lube-free operation
- 100% duty rating and unlimited duty cycles
- Low maintenance
- Low headroom, lightweight
- Sound absorption
- Insensitive to dust, humidity and temperatures ranging from -20°C up to +70°C
- From 1t upwards with overload protection (EC-version)

Technical Details

- Smooth starting, low maintenance vane motor
- Chain sprocket in the mid section runs in dust-proof maintenance-free ball bearings
- Planetary gear box with long-life grease lubrication, all gears made of tempered or hardened high-grade steel
- Load chain and hooks manufactured from high quality tempered steels with a breaking strength of five times the nominal load

The advantages at a glance

- **Strong – Fast – Silent**
High performance with more efficiency by reliability plus high lifting and lowering speeds. Low sound emissions.
 - **High Level of Safety**
Integrated emergency stop switch in the main air supply*.
From 1t upwards with overload protection.
 - **Oil-Free Operation**
Patented, permanent motor lubrication during operation, using a high-performance grease. No additional motor lubrication required.
 - **Patented Motor-Brake System**
For operation with low maintenance and little wear. Based on the proven design of the JDN Mini Series.
 - **Modern Design – Compact Size**
Features no protruding control hoses or parts susceptible to damage, making the PROFI also suitable for horizontal pulling.
 - **100% Duty Rating – No Downtime**
 - **Ex Classification according to EC Directive on Hazardous Locations 94/9/EEC**
As standard:
 II 2 GD IIA T4/II 3 GD IIB T4
With increased spark protection:
 II 2 GD IIC T4
- *up to PROFI 20 TI

JDN AIR HOISTS PROFI



The modular system at a glance

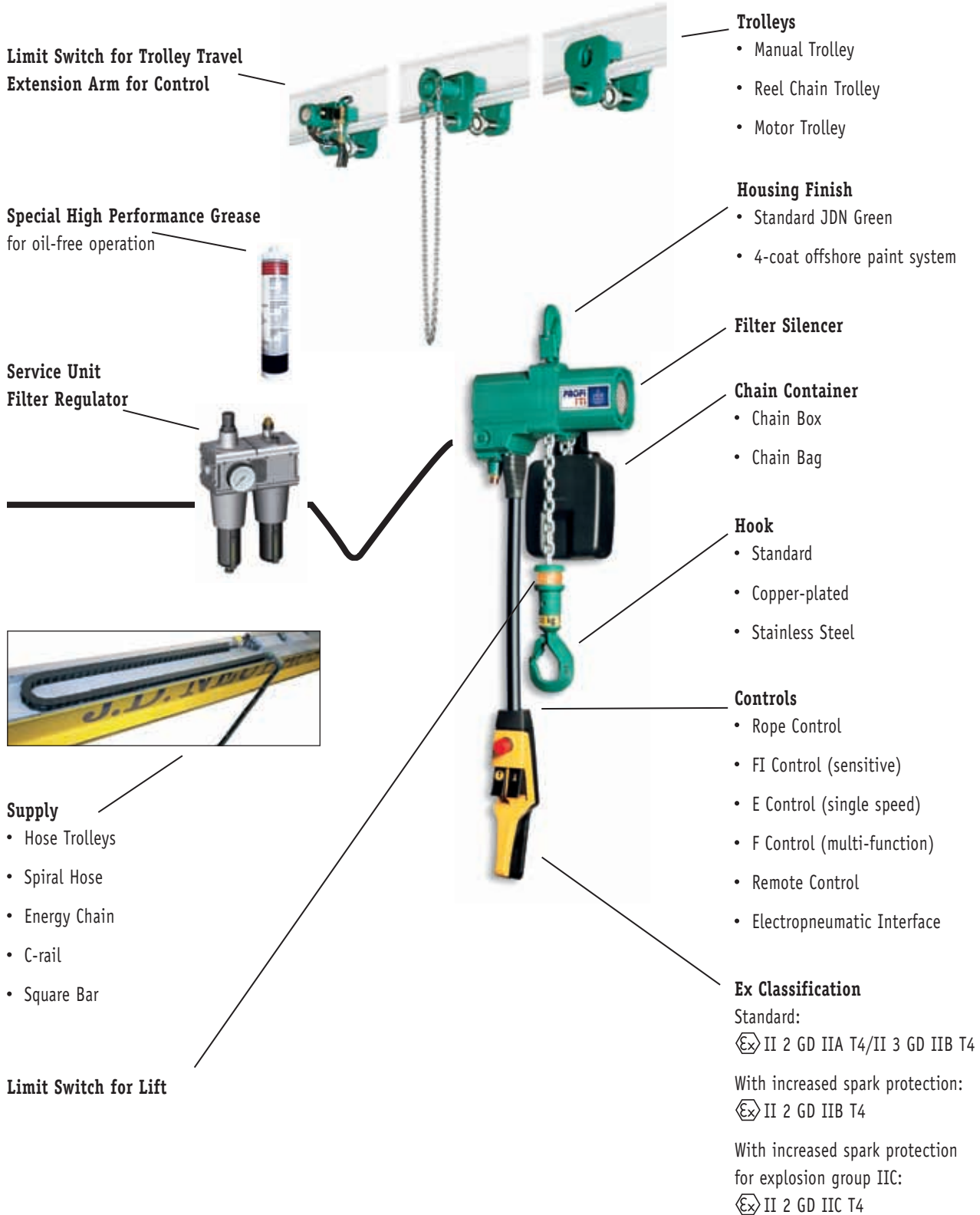



PROFI 025 TI – 2 TI

Technical Data

Type		025 TI		05 TI		1 TI		2 TI	
Air pressure	PSI	65	85	65	85	65	85	65	85
	bar	4	6	4	6	4	6	4	6
Carrying capacity	mt	0.16	0.25	0.32	0.5	0.63	1	1.25	2
Number of chain strands		1		1		1		2	
Motor output	kW	0.6	1.0	0.6	1.0	0.6	1.0	0.6	1.0
Lifting speed at full load	ft/min	65.6	65.6	32.8	36.1	16.4	18	8.2	8.9
	m/min	20	20	10	11	5	5.5	2.5	2.7
Lifting speed without load	ft/min	123	137.8	52.5	62.3	32.8	36.1	16.4	18
	m/min	37.5	42	16	19	10	11	5	5.5
Lowering speed at full load	ft/min	124.7	124.7	55.8	55.8	32.8	36.1	16.4	18
	m/min	38	38	17	17	10	11	5	5.5
Air consumption at full load – lifting	cfm	24.7	42.4	24.7	42.4	24.7	42.4	24.7	42.4
	m ³ /min	0.7	1.2	0.7	1.2	0.7	1.2	0.7	1.2
Air consumption at full load – lowering	cfm	28.3	53	28.3	53	28.3	53	28.3	53
	m ³ /min	0.8	1.5	0.8	1.5	0.8	1.5	0.8	1.5
Air connection		G 1/2		G 1/2		G 1/2		G 1/2	
Hose dimension (ø inside)	inch	1/2		1/2		1/2		1/2	
	mm	13		13		13		13	
Weight with standard lift, rope control	lbs	59.5	59.5	59.5	59.5	61.6	61.7 ¹	75 ¹	75 ¹
	kg	27	27	27	27	27.5	28 ¹	34 ¹	34 ¹
Chain dimension	mm	7 x 21		7 x 21		7 x 21		7 x 21	
Weight of chain	lbs/ft	0.67		0.67		0.67		0.67	
	kg/m	1.0		1.0		1.0		1.0	
Standard lift	ft	10		10		10		10	
	m	3		3		3		3	
Length of control at standard lift	ft	6.5		6.5		6.5		6.5	
	m	2		2		2		2	
Noise level at full load ² – lifting	dB(A)	73	74	74	75	74	76	74	76
Noise level at full load ² – lowering	dB(A)	77	78	77	78	77	78	77	78

¹With overload protection

²Measured at 1 m distance acc. to DIN 45635 part 20

Group mechanism at 6 bar: PROFI 025 TI M5 (2 m), PROFI 05 TI - PROFI 2 TI M4 (1 Am)



PROFI 1 TI

Dimensions

Type		025 TI	05 TI	1 TI	2 TI
A min. headroom ¹	inch	17.7	17.7	17.7	19.6
	mm	450	450	450	498
B	inch	11.3	11.3	11.3	13.2
	mm	288	288	288	336
C	inch	5.7	5.7	5.7	5.7
	mm	145	145	145	145
D	inch	11.7	11.7	11.7	11.7
	mm	297	297	297	297
E ₁	inch	1.1	1.1	1.1	1.1
	mm	28	28	28	28
E ₂	inch	1.1	1.1	1.1	1.1
	mm	28	28	28	28
F up to hook centre	inch	5.4	5.4	5.4	5.4
	mm	137	137	137	137
G maximum width	inch	6.9	6.9	6.9	7.2
	mm	176	176	176	183

¹Chain containers increase the hoist headroom

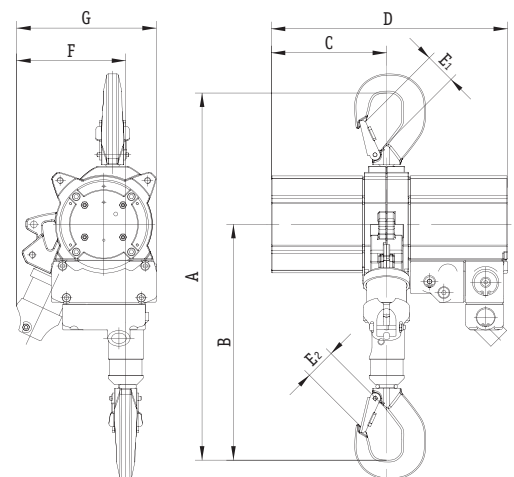

JDN AIR HOISTS PROFI



PROFI 1.5 TI and 3 TI/2

Technical Data

Type		1.5 TI	3 TI/2
Air pressure range	PSI bar	65-85 4-6	65-85 4-6
Capacity	mt	1.6	3.2
Number of chain strands		1	2
Motor output	kW	1.3-2	1.3-2
Lifting speed without load	ft/min m/min	27.6-32.8 8.4-10	13.8-16.4 4.2-5
Lifting speed at full load	ft/min m/min	13.1-19.7 4-6	6.6-9.8 2-3
Lowering speed at full load	ft/min m/min	36.1-39.4 11-12	18.0-19.7 5.5-6
Air consumption at full load – lifting	cfm m ³ /min	53-92 1.5-2.6	53-92 1.5-2.6
Air consumption at full load – lowering	cfm m ³ /min	78-127 2.2-3.6	78-127 2.2-3.6
Air connection		G 3/4	G 3/4
Hose dimension (Ø inside)	inch mm	3/4 19	3/4 19
Weight with standard lift, rope control	lbs kg	123 56	146 66
Chain dimension	mm	9 x 27	9 x 27
Weight of chain	lbs/ft kg/m	1.2 1.8	1.2 1.8
Standard lift	ft m	10 3	10 3
Length of control at standard lift	ft m	6,5 2	6,5 2
Noise level at full load ¹ – lifting	dB(A)	73-77	73-77
Noise level at full load ¹ – lowering	dB(A)	78-80	78-80

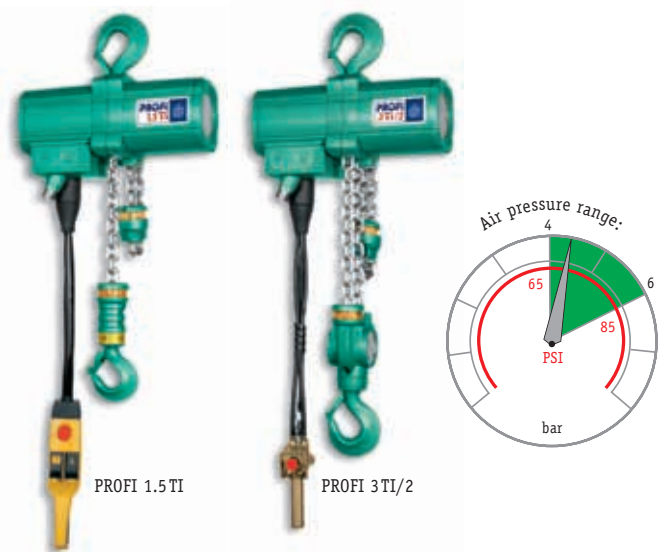

¹Measured at 1 m distance acc. to DIN 45635 part 20
Group mechanism: M3 (1 Bm)

Dimensions

Type		1.5 TI	3 TI/2
A min. headroom ¹	inch mm	18.9 480	21.4 544
B	inch mm	11.5 293	14.0 356
C	inch mm	7.9 200	7.9 200
D	inch mm	16.2 412	16.2 412
E ₁	inch mm	1.1 28	1.1 28
E ₂	inch mm	1.0 26	1.1 28
F up to hook centre	inch mm	6.7 170	5.5 140
G maximum width	inch mm	8.5 215	8.5 215

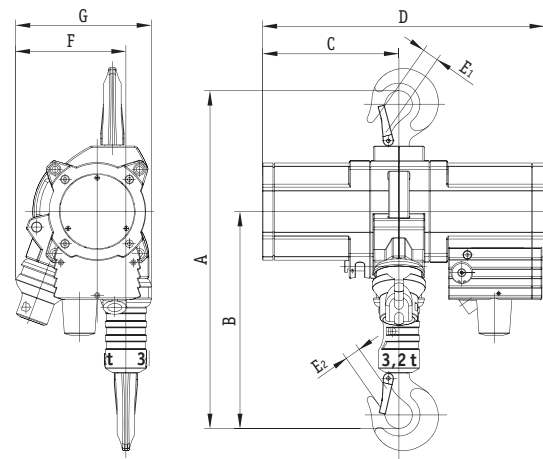

¹Chain containers increase the hoist headroom



PROFI 3 TI – 20 TI

Technical Data

Type		3 TI		6 TI		10 TI		16 TI		20 TI	
Air pressure	PSI	65	85	65	85	65	85	65	85	65	85
	bar	4	6	4	6	4	6	4	6	4	6
Capacity	mt	3.2		6.3		10		16		20	
Number of chain strands		1		2		2		3		4	
Motor output	kW	1.8	3.5	1.8	3.5	1.8	3.5	1.8	3.5	1.8	3.5
Lifting speed without load	ft/min	19.7	32.8	9.8	16.4	6.6	10.5	4.3	6.6	3.3	4.6
	m/min	6	10	3	5	2	3.2	1.3	2	1	1.4
Lifting speed at full load	ft/min	8.2	16.4	3.9	8.2	2.6	5.2	1.6	3.3	1.3	2.3
	m/min	2.5	5	1.2	2.5	0.8	1.6	0.5	1	0.4	0.7
Lowering speed at full load	ft/min	24.6	35.4	11.8	17.7	8.2	11.2	5.3	6.9	3.9	5.3
	m/min	7.5	10.8	3.6	5.4	2.5	3.4	1.6	2.1	1.2	1.6
Air consumption at full load – lifting	cfm	71	142	71	142	71	142	71	142	71	142
	m ³ /min	2	4	2	4	2	4	2	4	2	4
Air consumption at full load – lowering	cfm	124	195	124	195	124	195	124	195	124	195
	m ³ /min	3.5	5.5	3.5	5.5	3.5	5.5	3.5	5.5	3.5	5.5
Air connection		G 3/4		G 3/4		G 3/4		G 3/4		G 3/4	
Hose dimension (Ø inside)	inch	3/4		3/4		3/4		3/4		3/4	
	mm	19		19		19		19		19	
Weight with standard lift, rope control	lbs	189.6		242.5		343.9		529.1		627	
	kg	86		110		156		240		285	
Chain dimension	mm	13 x 36		13 x 36		16 x 45		16 x 45		16 x 45	
Weight of chain	lbs/ft	2.6		2.6		3.9		3.9		3.9	
	kg/m	3.8		3.8		5.8		5.8		5.8	
Standard lift	ft	10		10		10		10		10	
	m	3		3		3		3		3	
Length of control at standard lift	ft	6.5		6.5		6.5		6.5		6.5	
	m	2		2		2		2		2	
Noise level at full load ¹ – lifting	dB(A)	74	78	74	78	74	78	74	78	74	78
Noise level at full load ¹ – lowering	dB(A)	79	80	79	80	79	80	79	80	79	80

¹Measured at 1 m distance acc. to DIN 45635 part 20
Group mechanism at 6 bar: M3 (1 Bm)



PROFI 16 TI

Dimensions

Type		3 TI	6 TI	10 TI	16 TI	20 TI
A min. headroom ¹	inch	23.3	26.5	32	35.4	40.6
	mm	593	674	813	898	1030
B	inch	14.7	17.9	21.6	23.5	26.4
	mm	373	454	548	598	670
C	inch	9.2	9.2	12.1	15	15
	mm	233	233	308	382	382
D	inch	19	19	22.6	27.2	27.2
	mm	483	483	575	692	692
E ₁	inch	1.6	1.6	1.7	2.1	3
	mm	40	40	44	53	75
E ₂	inch	1.2	1.6	1.7	2.1	3
	mm	30	40	44	53	75
F up to hook centre	inch	7.4	6.1	7.8	7.8	7.1
	mm	187	154	197	199	180
G maximum width	inch	9.2	9.2	12	12.1	12.4
	mm	233	233	306	308	315

¹Chain containers increase the hoist headroom

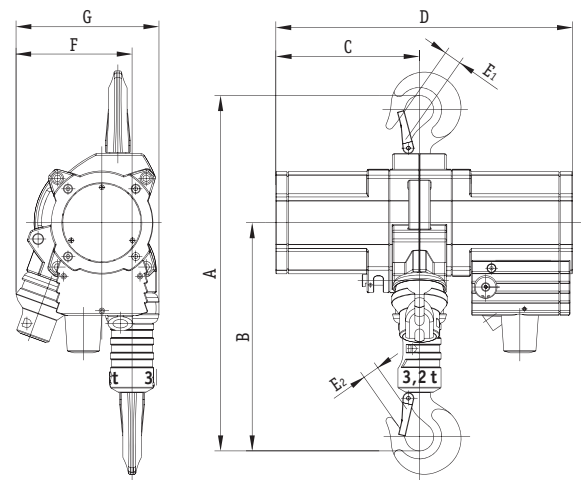

JDN AIR HOISTS PROFI



PROFI 25 TI – 100 TI

Technical Data

Type		25 TI	30 TI	37 TI	40 TI	50 TI	60 TI	75 TI	100 TI
Air pressure	PSI bar	85 6							
Capacity	mt	25	30	37.5	40	50	60	75	100
Number of chain strands		2	2	3	3	4	4	3	4
Motor output	kW	6.3						10.0	10.0
Lifting speed	ft/min m/min	7.9 2.4	7.9 2.4	5.6 1.7	5.6 1.7	4.3 1.3	4.3 1.3	2.8 0.85	2.3 0.7
Lifting speed at full load	ft/min m/min	4.1 1.25	3.3 1.0	2.5 0.75	2.3 0.7	1.8 0.55	1.5 0.45	1.5 0.45	1.1 0.35
Lowering speed at full load	ft/min m/min	9.2 2.8	9.2 2.8	6.6 2.0	6.6 2.0	5.3 1.6	5.3 1.6	3.3 1.0	2.6 0.8
Air consumption at full load - lifting	cfm m³/min	230 6.5						390 11	
Air consumption at full load - lowering	cfm m³/min	102 2.9						425 12	
Air connection		G 1 1/2							
Hose dimension (Ø inside)	inch mm	1 1/2 35							
Weight with standard lift, rope control	lbs kg	1213 550	1213 550	1874 850	1874 850	2072 940	2072 940	5622 2550	5820 2640
Chain dimension	mm	23.5 x 66						32 x 90	
Weight of chain	lbs/ft kg/m	8.2 12.2						14.3 21.3	
Standard lift	ft m	10 3							
Length of control at standard lift	ft m	6.5 2							
Noise level at full load ¹ - lifting	dB(A)	78						88	
Noise level at full load ¹ - lowering	dB(A)	82						89	



PROFI 50 TI

¹Measured at 1 m distance acc. to DIN 45635 part 20

Group mechanism at 6 bar: PROFI 25 TI - PROFI 50 TI M3 (1 Bm), PROFI 100 TI M2 (1 Cm)
4 bar versions on request

Dimensions

Type		25 TI	30 TI	37 TI	40 TI	50 TI	60 TI	75 TI	100 TI
A min. headroom ¹	inch mm	49.6 1260	49.6 1260	57.9 1470	57.9 1470	58.5 1485	58.5 1485	76.8 1950	86.6 2200
B	inch mm	32.6 827	32.6 827	36.8 935	36.8 935	37.4 950	37.4 950	50 1270	58.1 1475
C	inch mm	17.7 450	17.7 450	21.3 540	21.3 540	21.3 540	21.3 540	25.4 645	28.9 734
D	inch mm	35.4 900	35.4 900	42.5 1080	42.5 1080	42.5 1080	42.5 1080	50.8 1290	59.3 1505
E ₁	inch mm	3.0 75	3.0 75	3.9 100	3.9 100	3.9 100	3.9 100	4.7 120	4.7 120
E ₂	inch mm	3.0 75	3.0 75	3.9 100	3.9 100	3.9 100	3.9 100	4.7 120	4.7 120
F up to hook centre	inch mm	10.6 270	10.6 270	11.2 285	11.2 285	9.8 250	9.8 250	26 660	17.3 440
G maximum width	inch mm	17.5 445	17.5 445	17.7 450	17.7 450	16.9 430	16.9 430	41 1040	30.2 767

¹Chain containers increase the hoist headroom

